

LH534B00

CMOS 4M (512K × 8) Mask-Programmable ROM

FEATURES

- 524,288 words × 8 bit organization
- Access time: 120 ns (MAX.)
- Power consumption:
 - Operating: 330 mW (MAX.)
 - Standby: 550 μW (MAX.)
- Static operation
- TTL compatible I/O
- Three-state outputs
- Single +5 V power supply
- Package:
 - 40-pin, 10 × 20 mm² TSOP (Type I)

DESCRIPTION

The LH534B00 is a 4M-bit mask-programmable ROM organized as 524,288 × 8 bits. It is fabricated using silicon-gate CMOS process technology.

PIN CONNECTIONS

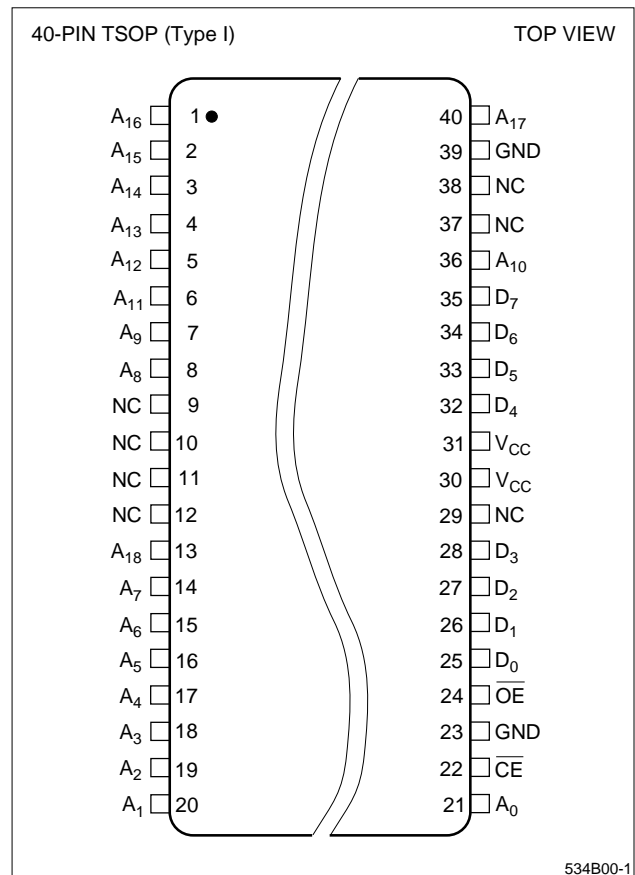

Figure 1. Pin Connections for TSOP Package

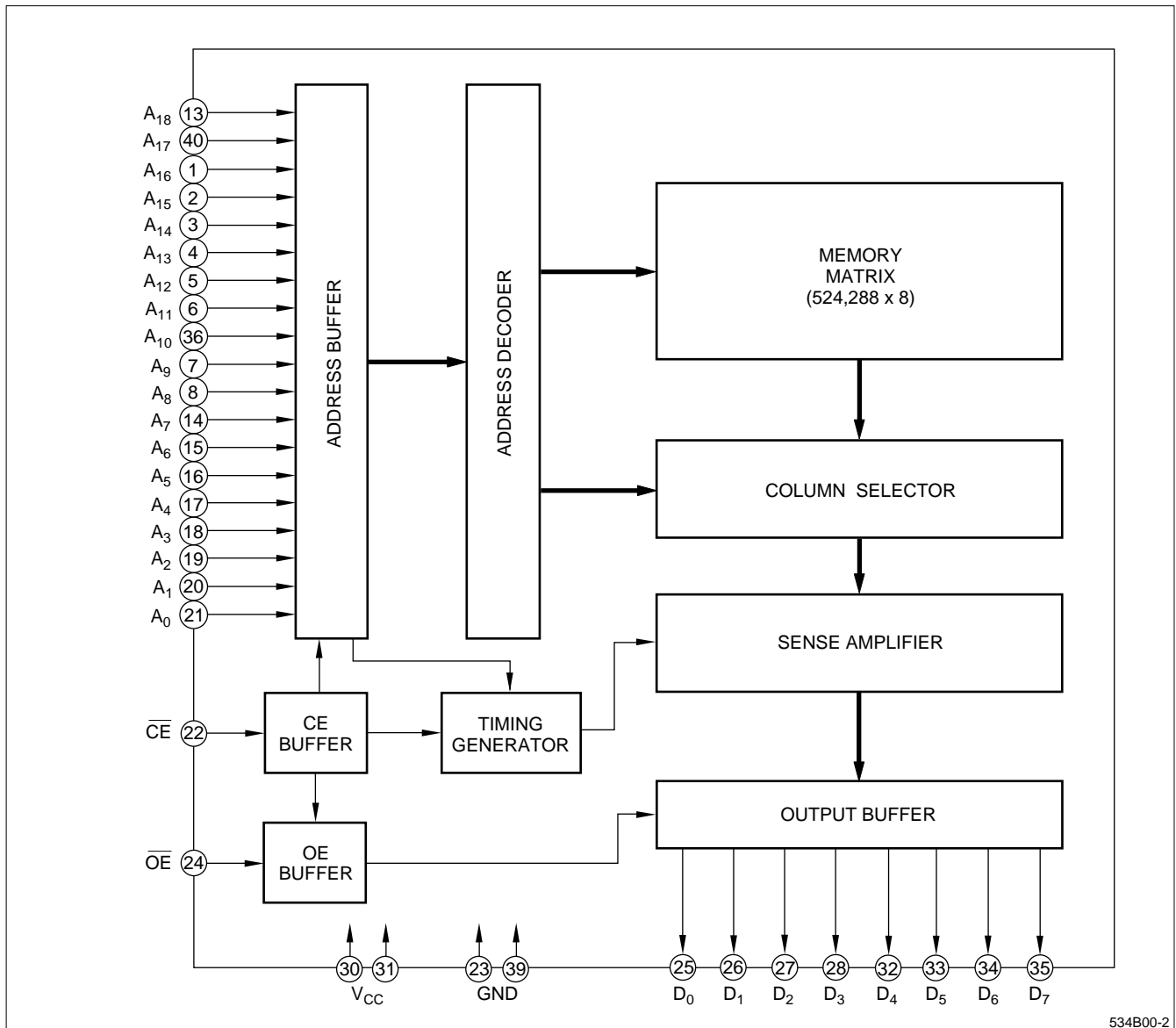

Figure 2. LH534B00 Block Diagram

PIN DESCRIPTION

SIGNAL	PIN NAME
A ₀ – A ₁₈	Address input
D ₀ – D ₇	Data output
\overline{CE}	Chip enable input
\overline{OE}	Output enable input

SIGNAL	PIN NAME
V _{CC}	Power supply (+5 V)
GND	Ground
NC	No connection

TRUTH TABLE

\overline{CE}	\overline{OE}	DATA OUTPUT	SUPPLY CURRENT
H	X	High-Z	Standby
L	H	High-Z	Operating
	L	Output	Operating

NOTE:

X = H or L, High-Z = High-impedance

ABSOLUTE MAXIMUM RATINGS

PARAMETER	SYMBOL	RATING	UNIT
Supply voltage	V_{CC}	-0.3 to +7.0	V
Input voltage	V_{IN}	-0.3 to $V_{CC} + 0.3$	V
Output voltage	V_{OUT}	-0.3 to $V_{CC} + 0.3$	V
Operating temperature	T_{opr}	-20 to +70	°C
Storage temperature	T_{stg}	-65 to +150	°C

RECOMMENDED OPERATING CONDITIONS ($T_A = -20^{\circ}\text{C}$ to $+70^{\circ}\text{C}$)

PARAMETER	SYMBOL	MIN.	TYP.	MAX.	UNIT
Supply voltage	V_{CC}	4.5	5.0	5.5	V

DC CHARACTERISTICS ($V_{CC} = 5\text{ V} \pm 10\%$, $T_A = -20^{\circ}\text{C}$ to $+70^{\circ}\text{C}$)

PARAMETER	SYMBOL	CONDITIONS	MIN.	MAX.	UNIT	NOTE
Input 'High' voltage	V_{IH}		2.2	$V_{CC} + 0.3$	V	
Input 'Low' voltage	V_{IL}		-0.3	0.8	V	
Output 'High' voltage	V_{OH}	$I_{OH} = -400\ \mu\text{A}$	2.4		V	
Output 'Low' voltage	V_{OL}	$I_{OL} = 2.0\ \text{mA}$		0.4	V	
Input leakage current	$ I_{LI} $	$V_{IN} = 0\ \text{V}$ to V_{CC}		10	μA	
Output leakage current	$ I_{LO} $	$V_{OUT} = 0\ \text{V}$ to V_{CC}		10	μA	1
Operating current	I_{CC1}	$t_{RC} = 120\ \text{ns}$		60	mA	2
	I_{CC2}	$t_{RC} = 1\ \mu\text{s}$		50	mA	2
	I_{CC3}	$t_{RC} = 120\ \text{ns}$		55	mA	3
	I_{CC4}	$t_{RC} = 1\ \mu\text{s}$		45	mA	3
Standby current	I_{SB1}	$\overline{CE} = V_{IH}$		3	mA	
	I_{SB2}	$\overline{CE} = V_{CC} - 0.2\ \text{V}$		100	μA	
Input capacitance	C_{IN}	$f = 1\ \text{MHz}$		10	pF	
Output capacitance	C_{OUT}	$T_A = 25^{\circ}\text{C}$		10	pF	

NOTES:

- $\overline{CE}/\overline{OE} = V_{IH}$
- $V_{IN} = V_{IH}$ or V_{IL} , $\overline{CE} = V_{IL}$, outputs open
- $V_{IN} = (V_{CC} - 0.2\ \text{V})$ or $0.2\ \text{V}$, $\overline{CE} = 0.2\ \text{V}$, outputs open

AC CHARACTERISTICS ($V_{CC} = 5\text{ V} \pm 10\%$, $T_A = -20^\circ\text{C}$ to $+70^\circ\text{C}$)

PARAMETER	SYMBOL	MIN.	MAX.	UNIT	NOTE
Read cycle time	t_{RC}	120		ns	
Address access time	t_{AA}		120	ns	
Chip enable access time	t_{ACE}		120	ns	
Output enable delay time	t_{OE}		60	ns	
Output hold time	t_{OH}	0		ns	
CE to output in High-Z	t_{CHZ}		60	ns	1
OE to output in High-Z	t_{OHZ}				

NOTE:

1. This is the time required for the outputs to become high-impedance.

AC TEST CONDITIONS

PARAMETER	RATING
Input voltage amplitude	0.4 to 2.6 V
Input rise/fall time	10 ns
Input/output reference level	1.5 V
Output load condition	1 TTL + 100 pF

CAUTION

To stabilize the power supply, it is recommended that a high-frequency bypass capacitor be connected between the V_{CC} pin and the GND pin.

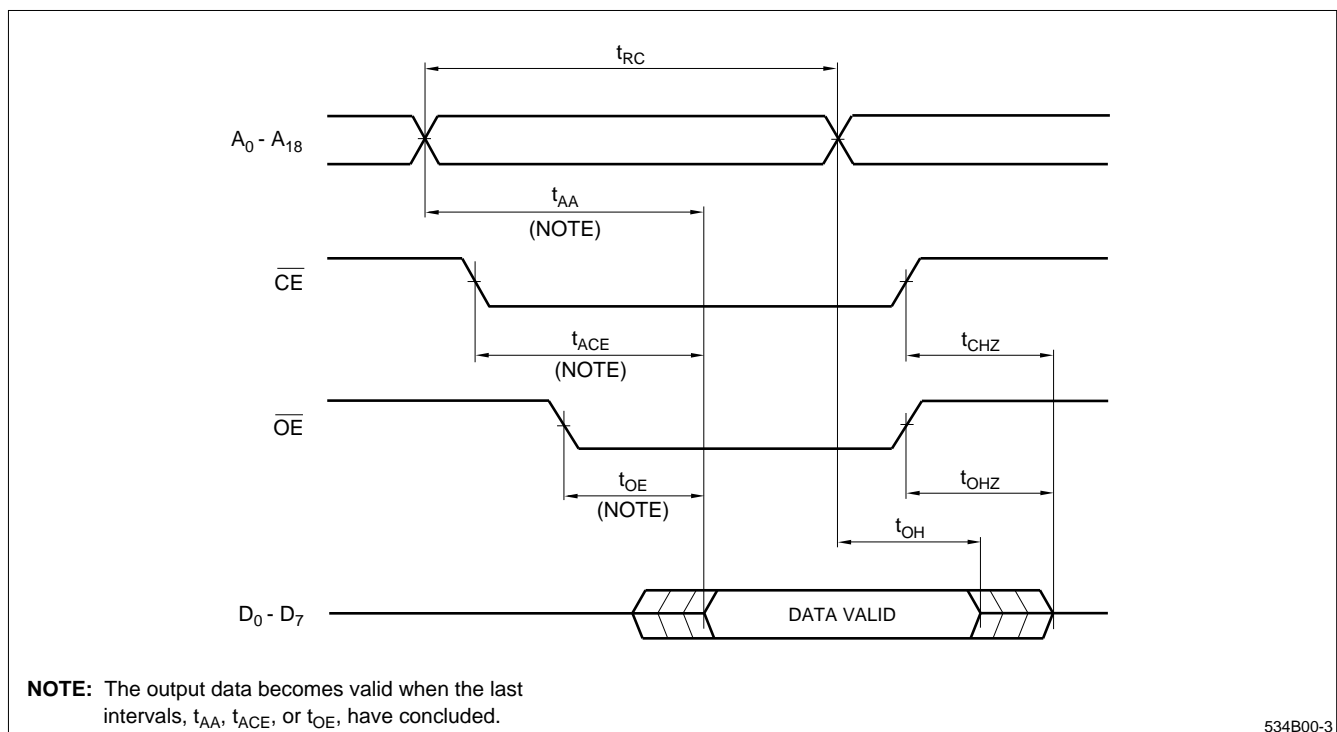
**Figure 3. Timing Diagram**

PACKAGE DIAGRAM

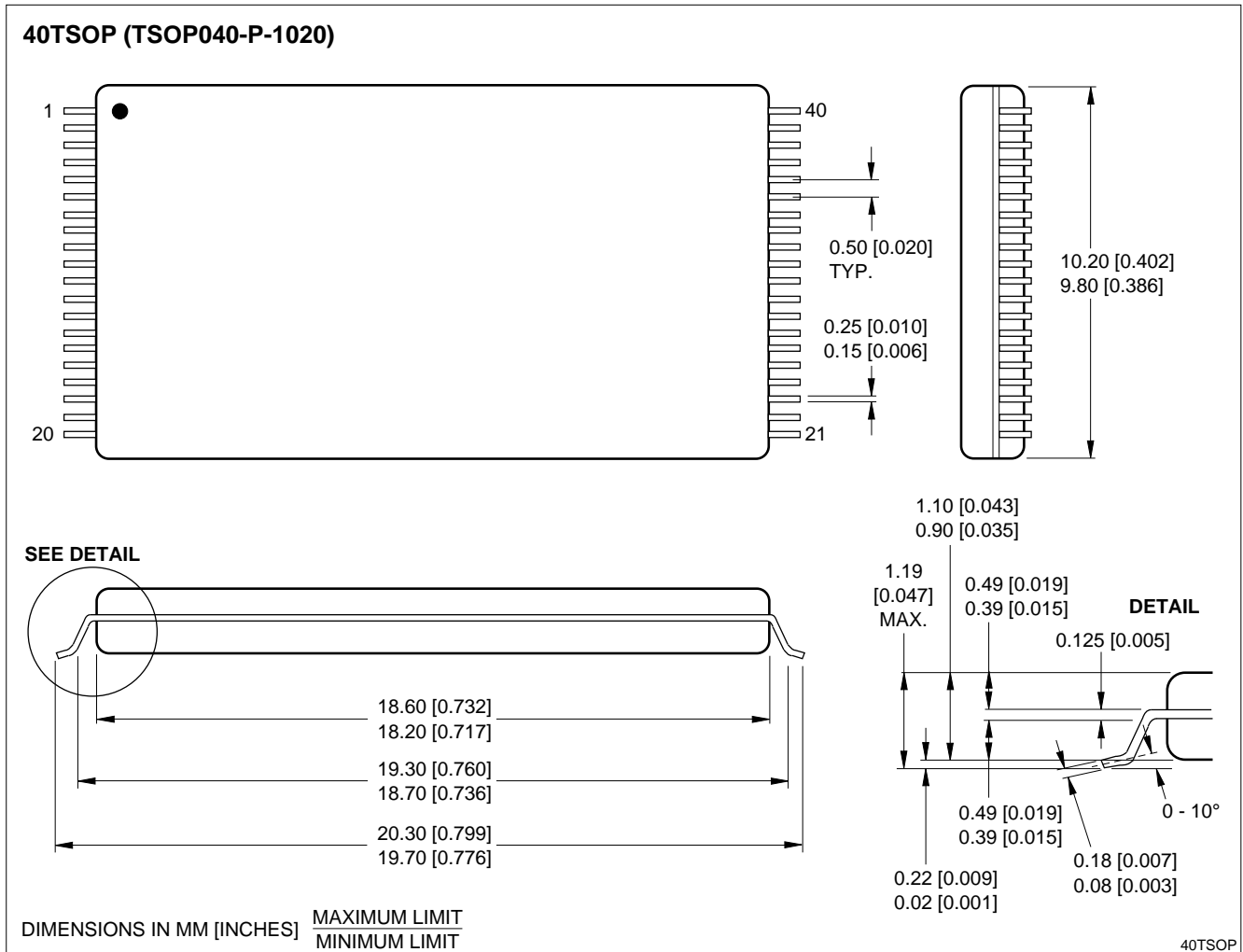

40-pin, 10 × 20 mm² TSOP (Type I)

ORDERING INFORMATION

